



Enriching Lives

PROCESS PUMPS

TYPE - KPD / KPD-QF



KIRLOSKAR BROTHERS LIMITED

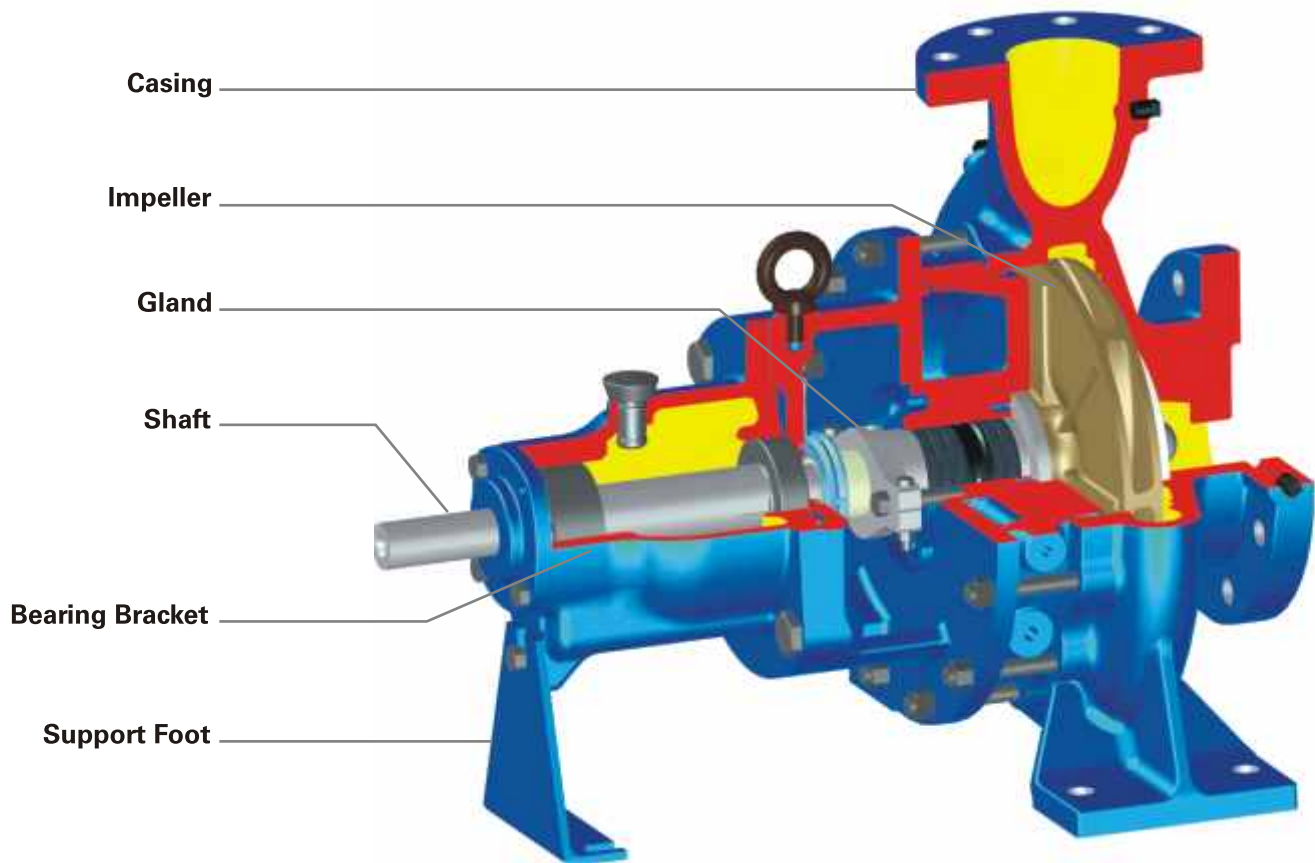

RANGE

Delivery size : up to 200 mm
 Capacity : up to 900 m³/hr
 Head : up to 225 metres
 Working Pressures : 16-30 kg/cm²
 Temperature : (-)50°C to +350°C

APPLICATIONS

Chemical Process Industries, Petro Chemical, Nuclear, Refinery, Paper and Power Plants etc.
 Pumps suitable for handling Corrosive Acids, Alkalies, Salt Solutions, Caustics, Hydro Carbons, Oils, Thermic Fluids, Liquefied Gases, Condensates, Viscous Liquids etc.

FEATURES

Pumps are as per EN 22858 (DIN 24256) and ISO 2858. The design is of back pull out type. Large variety of models are available to operate at 1450 rpm and 2900 rpm at 50Hz.

Casing :

The casing has axial suction and top centre line delivery. Smooth hydraulic passages ensure high efficiency. Normal design is for foot mounted pumps. Centre line mounting for special applications are also available.

Impeller :

The impellers are of enclosed type and semi-open impellers can also be supplied. Hydraulic balancing of impellers is achieved either by back vanes or by balancing holes. The impellers are statically and dynamically balanced. Reliable fixing of the impeller on shaft is achieved by using helicoil insert under impeller nut. To improve NPSH performance, inducer can be supplied.

Shaft :

The shaft is supported by two antifriction bearings to take residual axial thrust and prevent axial float or radial run out. It is fully protected from the liquid handled by means of a shaft sleeve and gaskets between impeller nut, impeller hub and shaft sleeve.

Stuffing Box :

The stuffing box is sealed by gland packing or by cartridge type mechanical seal. Conversion from gland packing to mechanical seal is achieved by changing some standardised parts. Re-machining of stuffing box is not necessary. Stuffing box cooling is provided for operating temperature 105°C for gland packed and 140°C for mechanical seal fitted pumps.

Bearing :

The bearings are oil lubricated. For high temperature (above 180°C) application, bearing oil cooling arrangement is provided. All pumps are provided with reinforced bearing arrangement as standard supply.

Direction of Rotation :

Clockwise viewed from driving end.

Drive :

Pumps can be driven by electric motor or engine.

Flanges :

ANSI B 16.1, CL 125 Flat Face : for CI/BR

ANSI B 16.5, CL 150 Raised Face - for sp.metals viz. st. steel, cast steel etc.

Drilling as per DIN, ASA, BS etc. (Optional)

GENERAL DIMENSIONS / MOUNTING DETAILS

Centreline Mounted (CLM) Pump

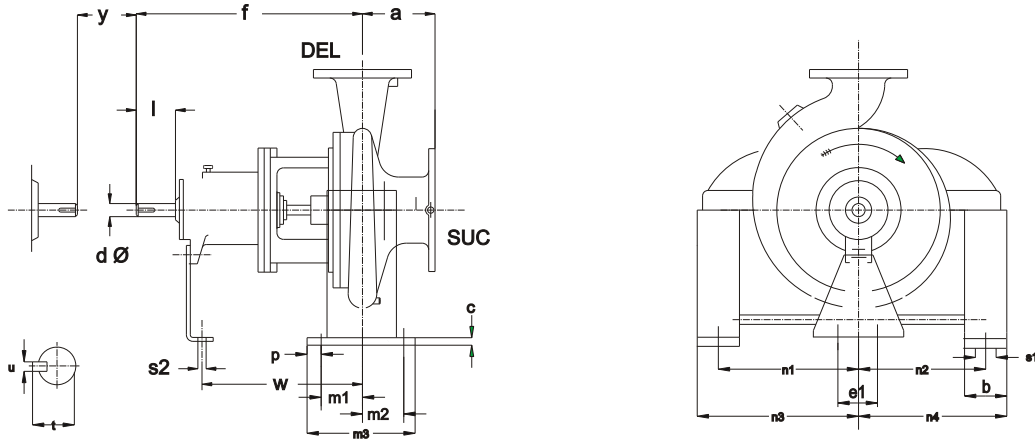

Pump Type	Drv. Unit	Pump Dimensions						Foot Dimensions														Shaft End				
		SUC	DEL	a	f	h1	h2	b	c	m1	m2	m3	n1	n2	n3	n4	w	s1	s2	e1	p	d	l	t	u	y
0/ 13CF	4	25	20	80	385	200	64	15	72	88	190	125	125	157	157	285	14	14	110	23	18	40	20.5	6	100	
20/16QF												130	130	162	162											
20/20QF												155	155	187	187											
25/16QF												155	145	187	177											
32/13	5	50	32	80	385	200	64	15	72	88	190	125	125	157	157	285	14	14	110	23	18	40	20.5	6	100	
32/16												155	145	187	177											
32/20												170	165	202	197											
40/13												135	125	167	157											
40/16	5	65	40	80	385	200	64	15	72	88	190	170	165	202	197	285	14	14	110	23	18	40	20.5	6	100	
40/20												170	165	202	197											
50/13												160	155	187	177											
50/16												180	170	202	197											
50/20	5	80	50	100	385	200	64	15	72	88	190	170	165	202	197	285	14	14	110	23	18	40	20.5	6	100	
65/13												180	170	202	197											
25/26A												200	190	210	207											
32/26												225	215	235	230											
40/26	7	65	40	125	500	250	90	89.5	110.5	230	260	240	305	285	370	15	110	32	80	35	10	140				
40/32												250	240	260									275			
50/26												225	215	235									230			
50/32												280	270	290									285			
65/16	7	100	65	100	500	250	90	89.5	110.5	230	260	230	305	275	370	15	110	32	80	35	10	140				
65/20												250	240	260									275			
65/26												225	215	235									230			
80/16												280	270	290									285			
80/20	7	125	80	125	500	250	90	89.5	110.5	230	260	230	305	275	370	15	110	32	80	35	10	140				
80/26												250	240	260									275			
100/20												225	215	235									230			
65/32												280	270	290									285			
80/32	9	100	65	140	530	315	315	18	100	150	300	310	295	355	340	483.5	27	19	140	30	60	110	64.4	18	180	
80/40												365	355	375	370											
100/26												280	270	290	285											
100/32												315	315	335	330											
100/40	9	125	80	140	530	315	315	15	92.5	107.5	230	260	230	305	275	483.5	27	19	140	30	60	110	64.4	18	180	
125/26												365	355	375	370											
125/32												280	270	290	285											
125/40												315	315	335	330											
150/32	9	200	150	160	530	315	365	18	100	150	300	355	315	400	360	483.5	27	19	140	30	60	110	64.4	18	180	
150/40												385	345	430	390											
125/26												400	365	450	400											
200/38M												425	550	550	550											
200/46	13	250	200	200	670	400	500	100	22	120	160	340	450	410	505	465	483.5	27	19	140	30	60	110	64.4	18	180
150/52												440	395	495	450											

GENERAL DIMENSIONS / MOUNTING DETAILS

Foot Mounted (FM) Pump

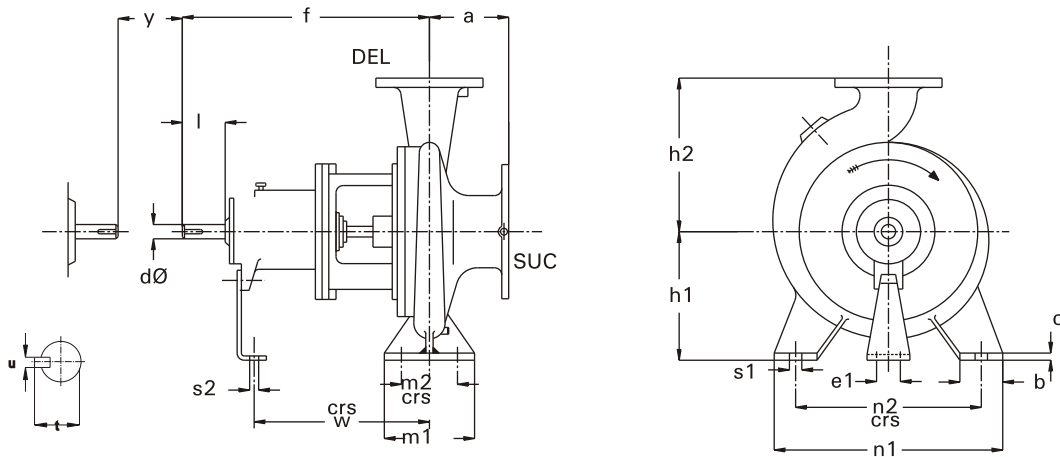

Pump Type	Drg. Unit	Pump Dimensions					Foot Dimensions										Shaft End					Wt. Kg.	
		SUC	DEL	a	f		h1	h2	b	c	m1	m2	n1	n2	w	s1	s2	e1	dØ	l	t		u
0/ BCF #						100	140			80	50	190	140										1
20/16QF #	4	25	20	80	385	132	150	50	10			210	160	285	14	14	110	18	40	20.5	6	100	38
20/20QF #						160	170			100	70	240	190										43
25/16QF #		40	25	100		132	165		14			210	160										36
25/20QF #							180		10	80	50	265	212		11.5								44
32/13		50	32			112	140					190	140										38
32/16				80		132	160					240	190										40
32/20						160	180																47
40/13						112	140					210	160										39
40/16	5	65	40		385	132	160	50	14	100	70	240	190	285	14	15	110	24	50	27	8	100	42
40/20						160	180					265	212										48
50/13						132	160					240	190										42
50/16		80	50	100		160	180					265	212										46
50/20							200																53
65/13		100	65			160	180	65		125	95	280	212										69
25/26		50	25			180	225	65		125	95	320	250										90
32/26		50	32	100		180	225					320	250										90
40/26		65	40	125																			90
40/32						200	250					345	280										103
50/26		80	50	125	500	180	225	65	14	125	95	320	250		14								90
50/32						225	280					345	280										120
65/16				100		160	200					280	212										77
65/20	7	100	65			180	225					320	250	370		15	110	32	80	35	10	140	79
65/26						200	250	80	16	160	120	360	280		18								96
80/16						180	225	65	14	125	95	320	250		14								85
80/20		125	80	125			250					345	280										86
80/26						225	280					400	315		18								116
100/20		125	100			200	280	80	16	160	120	360	280										106
65/32		100	65			225	280					400	315										140
80/32						250	315																146
80/40		125	80	125	530	280	355	80	16	160	120	435	355	370	18								181
100/26						225	280					400	315										134
100/32		125	100			250	315									15	110	42	110	45	12	140	157
100/40	9			140		280	355	100	18	200	150	500	400		23								164
125/26						250	355	80	16	160	120	400	315		18								158
125/32		150	125			280	355		18					370									179
125/40						315	400	100		200	150	500	400		23								212
150/32		200	150	160		315	400		22														260
150/40 \$		200	150	160		315	450	100	18	200	150	550	450		23								285

All dimensions are in mm

GENERAL OUTLINE DIMENSIONS

KPD / KPD-QF (FM) Pump

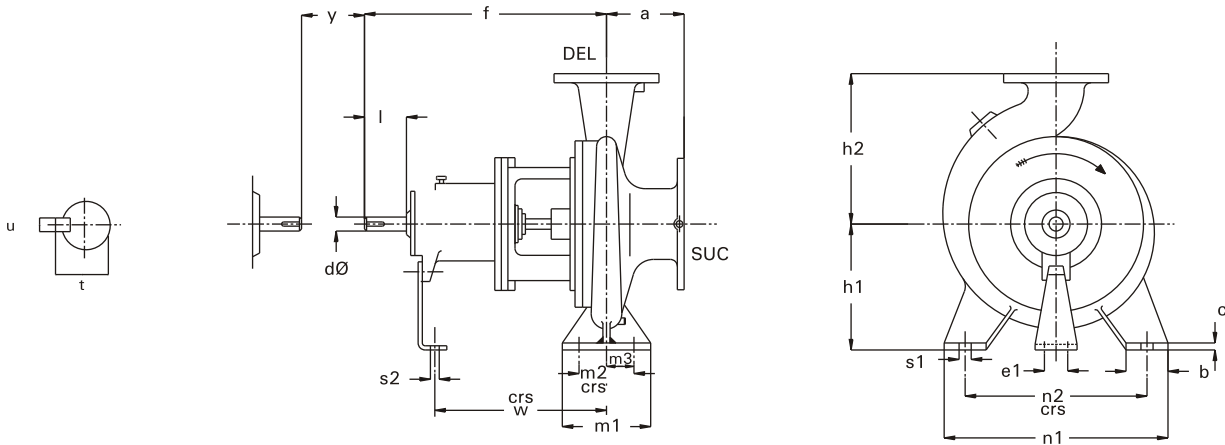

Pump Size	Driving Unit	Pump Dimensions						Foot Dimensions										Shaft End					Wt. Kg.	
		SUC	Del	a	f	h1	h2	b	c	m1	m2	m3	n1	n2	w	s1	s2	e1	d*	l	t	u		y
125/45 \$	11A	150	125	160	670	350	450	100	20	180	120	70	550	450	500	23	19	140	48	110	51.4	14	180	290
150/43 \$	11B	200	150	160	685	350	475	100	20	180	120	90	550	450	514	23	19	140	48	110	51.4	14	180	300
65/43 \$	9	100	65	160	530	280	365	80	18	160	120	60	435	355	370	18	15	110	42	110	45	12	140	195

Pump Size	Driving Unit	Pump Dimensions						Foot Dimensions										Shaft End					Wt. Kg.
		DEL	SUC	a	f	h1	h2	b	c	m1	m2	n1	n2	w	s1	s2	e1	dØ	l	t	u	y	
100/16	7	100	125	150	500	225	280	65	14	125	95	320	250	370	14	15	110	32	80	35	10	140	97
125/20	9	125	125	140	530	250	315	80	16	160	120	400	315	370	18	15	110	42	110	45	12	140	138
125/26	11	125	150	140	670	280	355	80	16	160	120	400	315	500	18	19	140	48	110	51.5	14	140	190
150/26	9	150	200	160	530	280	375	100	20	200	150	500	400	370	23	15	110	42	110	45	12	140	175
150/52 \$		150	200	200	670	400	550	150	30	240	180	650	530	483	27	19	140	60	110	64.4	18	180	435
200/38M \$	13	200	250	200	670	400	500	120	30	240	180	550	430	483.5	27	19	140	60	110	64.4	18	180	550
200/46 \$		200	250	200	670	425	550	120	30	240	180	640	540	483.5	27	19	140	60	110	64.4	18	180	560
80/40DV	11	80	125	125	670	280	355	80	16	160	120	435	355	500	18	19	140	48	110	51.5	14	180	177
100/40DV	11	100	150	140	670	280	355	100	18	200	150	500	400	500	23	19	140	48	110	51.5	14	180	200

Note :

These pumps provided with semi open impeller only.

\$ These pumps cannot be supplied with semi open impeller.

All dimensions are in mm

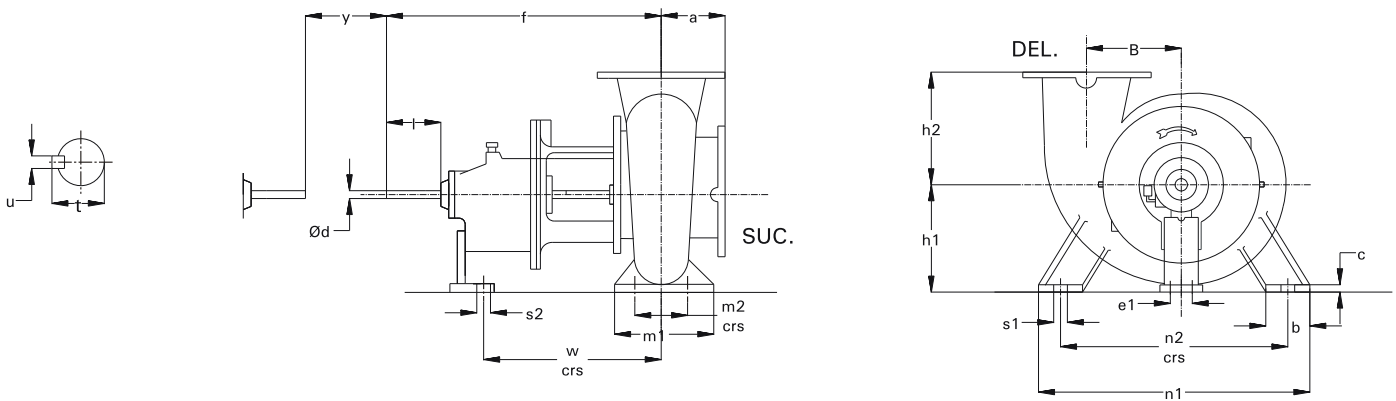

Pump Size	Driving Unit	Pump Dimensions						Foot Dimensions										Shaft End					Wt. Kg.	
		SUC	Del	a	F	H1	h2	B	b	c	m1	m2	n1	n2	w	s1	s2	e1	Ød4	l	t	u		y
200 / 33	11C	200	200	200	720	370	315	265	100	25	335	265	630	560	650	27	19	140	48	110	51.4	14	180	280

CROSS-SECTIONAL VIEW

KPD Pump

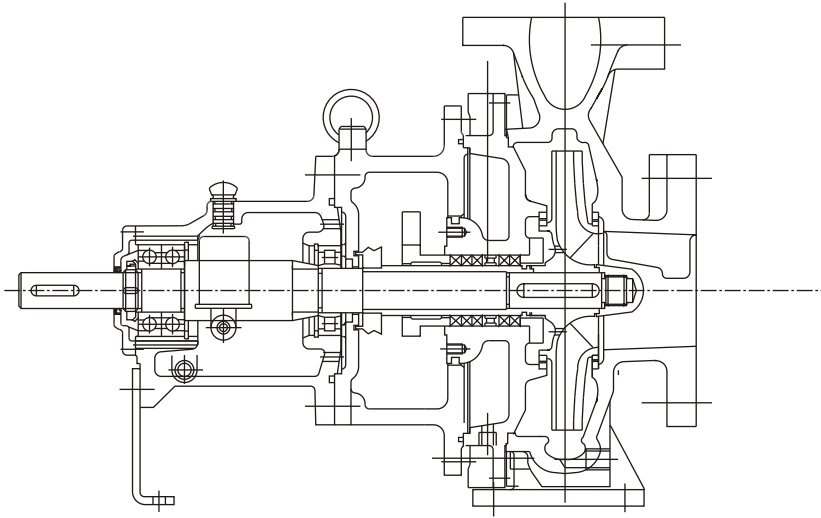

INTERCHANGEABILITY OF COMPONENTS

Pump Unit	Size	Casing	Impeller	Casing Cover	Bearing Housing & Shaft
5	32/13	1	1	1	1
	40/13	2	2		
	50/13	3	3		
	65/13	4	4		
	32/16	5	5	2	
	32/16A	6	6	3	
	40/16	7	7	2	
	50/16	8	8	2	
	50/16A	9	9	3	
	32/20	10	10	4	
	32/20A		11	5	
	40/20	11	12	4	
	40/20A	12	13	5	
	50/20	13	14	4	
7	65/16	14	15	6	2
	80/16	15	16	7	
	65/20	16	17		
	80/20	17	18		
	100/20	18	19	8	
	25/26	19	20		
	32/26	20	21	9	
	40/26	21	22		
	50/26	22	23		
	65/26	23	24		
	65/26N		25		
	80/26	24	26		
	40/32	25	27	10	
	50/32	26	28	11	
	100/16	27	29	12	
	9	100/26	28	30	
125/26		29	31		
65/32 (1450 rpm)		30	32		
65/32 (2900 rpm)			33		
80/32		31	34	14	
100/32		32	35		
125/32		33	36	15	
150/32		34	37		
150/32N			38		
80/40		35	39	16	
80/40N		36	40		
100/40			41		
125/40		37	42		
125/40N		40	43		
125/20			46	20	
150/26		41	47	21	
150/40		38	44	18	
65/43		39	45	19	
80/40DV	42	48	17		
11	125/26 (2900 rpm)	29	31	20	4
11		43	41		
11		44	41		
11/A	125/45	44	50	21	5
11/B	150/43	45	51	22	6
11/C	200/33	46	49	23	7
13	150/52	47	52	24	8
	200/38M	48	53	25	
	200/46	49	54	26	

GENERAL OUTLINE DIMENSIONS

KPD-QF Pump

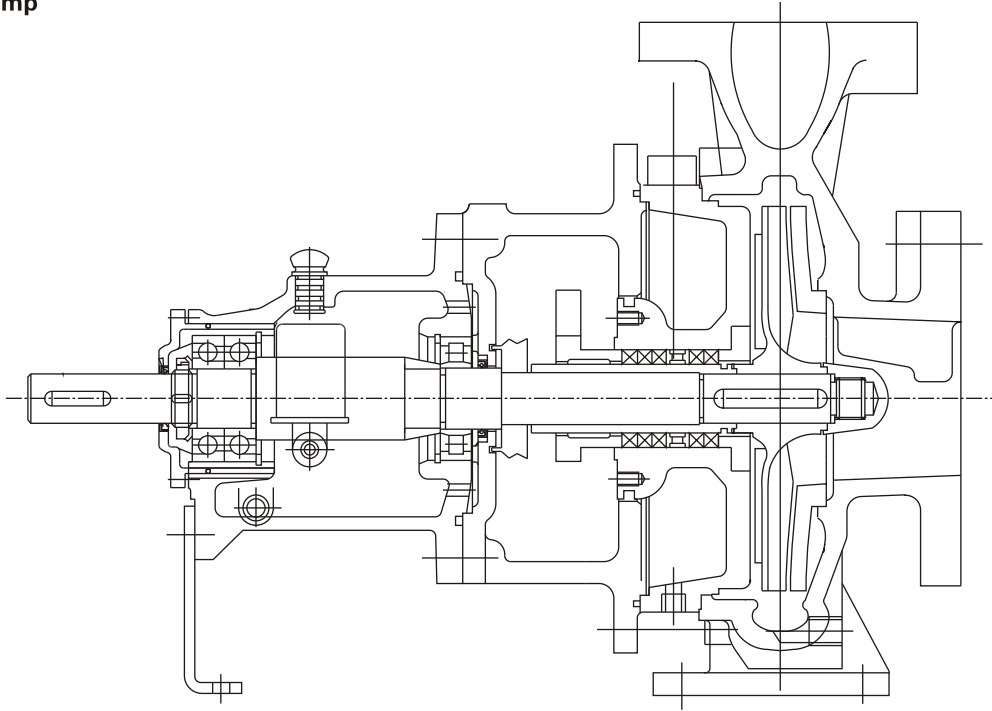

INTERCHANGEABILITY OF COMPONENTS

Pump Unit	Size	Casing	Impeller	Casing Cover	Bearing Housing & Shaft
4	20/13	1	1	1	1
	20/16	2	2	2	
	20/20	3	3	3	
5	32/13	4	4	4	2
	40/13	5	5		
	50/13	6	6		
	65/13	7	7		
	25/16	8	8	5	
	32/16	9	9	6	
	40/16	10	10	7	
	50/16	11	11	8	
	32/20	12	12		
	40/20	13	13		
50/20	14	14	9		
7	65/16	15	15	10	3
	80/16	16	16		
	65/20	17	17	11	
	80/20	18	18		
	100/20	19	19	12	
	32/26	20	20	13	
	40/26	21	21		
	50/26	22	22	14	
	65/26	23	23		
	80/26	24	24	15	
	40/32	25	25	16	
50/32	26	26			
9	100/26	27	27	17	4
	125/26	28	28		
	65/32	29	29	18	
	80/32	30	30		
	100/32	31	31		
	125/32	32	32		
	150/32	33	33	19	
	80/40	34	34	20	
	100/40	35	35	21	
	125/40	36	36	22	

BACK PULL OUT ARRANGEMENT

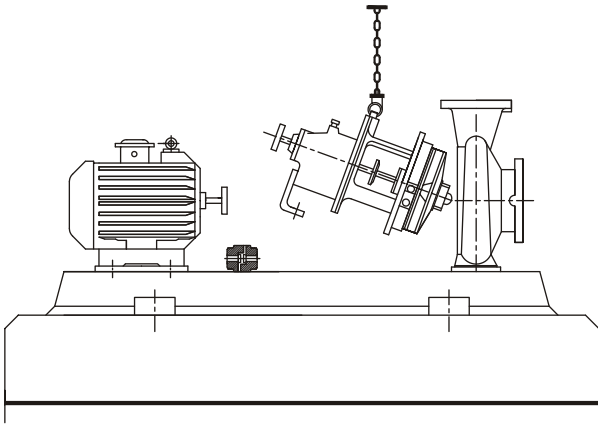

Using spacer type coupling, back-pullout design enables the pump rotating unit to be removed without disturbing the pipe connections. The prime mover is also undisturbed. This reduces servicing time, resulting in lower maintenance costs and reduction in production losses.

ALTERNATIVES AVAILABLE

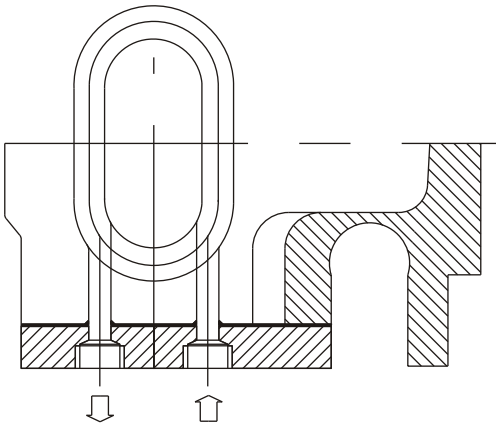

Bearing Oil Cooling Arrangement

For high temperature applications above 180°C bearing oil cooling arrangement is provided.

Steam Jacket Arrangement

This special design can be offered for handling liquids that cannot be pumped when cold. Except for pump casing, casing cover and gland, all parts are of standard design.

Steam Jacket Arrangement

WORKING TEMPERATURE AND PRESSURE

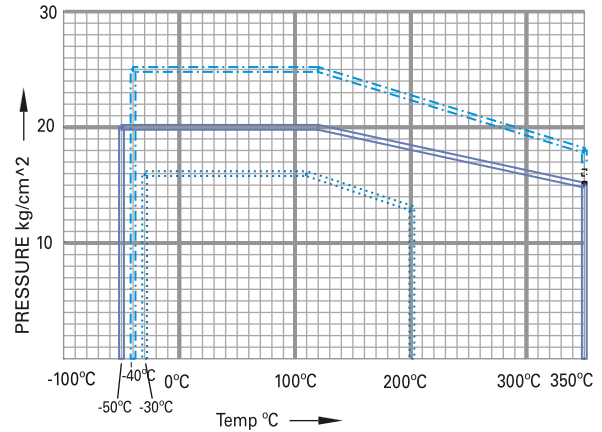

Note :

The pressure and temperature data holds good only if flanges are suitable to a particular operating pressure and temperature.

	CAST ST & ST. STEEL
	S.G. IRON
	C.I. & BRONZE

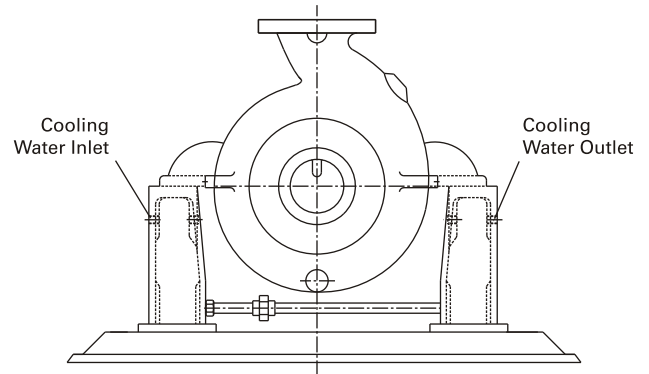

Centre line Mounting

For high temperature applications between 180°C and 350°C, pumps are offered with centreline mounting.

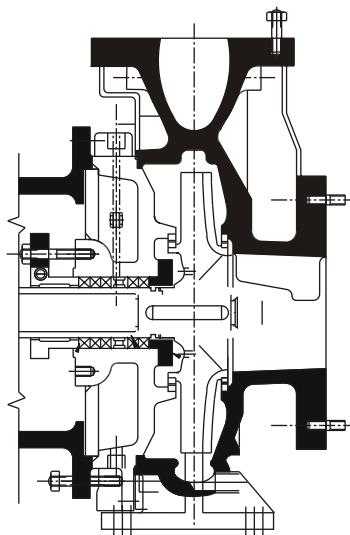

MATERIALS

MATERIAL OF CONSTRUCTION

Casing / Casing Cover	Cast Iron / Cast Steel / Stainless Steel / Duplex Steel
Impeller	Cast Iron / Bronze / Cast Steel / Stainless Steel / Chrome Steel / Duplex Steel
Wear Ring / Wear Plate	Cast Iron / Bronze / Steel
Shaft	Carbon Steel / Stainless Steel / Duplex Steel
Shaft Sleeve	Stainless Steel / Bronze

MATERIAL STANDARDS - GENERAL INFORMATION

Material Type	Indian Standard (IS)	American Standard (ASTM)	DIN
Cast Iron			
Cast Iron	IS 210 Gr. FG 260	ASTM A48 Class 40	(0.6025)DIN 1691 GG25
Spheroidal Graphite Cast Iron			
SG Iron (Ductile Iron)	IS 1865 Gr 400/15	A536, 60-40-18	(0.7040)DIN1693 GGG40
SG Iron (Ductile Iron)	IS 1865 Gr 500/7	A536, 65-45-12	(0.7050)DIN1693 GGG50
Carbon Steel			
Carbon steel (Wrought)	IS 1570 (part II) Gr. 40C8	ASTM A107 Gr. 1040	(1.1186)C40E/CK40
Carbon steel (Wrought)	IS 1570 (part II) Gr. 20C8	ASTM A107 Gr. 1020	(1.0402)C22
MS Steel	MS IS 2062 - Fe 410 W A	ASTM-A283 GR.D FABRICATED STEEL44	DIN 1700 GR ST4-2
Cast Steel Grades			
Cast Steel		ASTMA 216 Gr. WCB	1.0619(GS-C25)
Cast Stainless Steel			
Stainless Steel CF8M	IS 3444 Gr. 4	ASTMA 351 Gr. CF8M	1.4408(GX5CrNiMo19-11-2)
Stainless Steel CF8M	IS 3444 Gr. 4	ASTMA 743 Gr. CF8M	1.4408(GX5CrNiMo19-11-2)
Stainless Steel CF3M	IS 3444 Gr. 16	ASTMA 351 Gr. CF3M	1.4409(GX2CrNiMo19-11-2)
Stainless Steel CF3M	IS 3444 Gr. 16	ASTMA 743 Gr. CF3M	1.4409(GX2CrNiMo19-11-2)
Stainless Steel CF8	IS 3444 Gr. 1	ASTMA 351 Gr. CF8	1.4301(X5CrNi18-10)
Stainless Steel CF3	IS 3444 Gr. 15	ASTMA 351 Gr. CF3	1.4306(X2CrNi19 11)
Cast Chromium Stainless Steel			
Stainless Steel CA15	IS 3444 Gr. 10	ASTMA 217 Gr. CA15	1.4106&1.448(DIN17445 GX12Cr14)
Stainless Steel CA15	IS 3444 Gr. 10	ASTMA 743 Gr. CA15	1.4106&1.448(DIN17445 GX12Cr14)
Stainless Steel CA6NM	IS 3444 Gr. 24	ASTMA 487 Gr. CA6NM	1.4313&1.4317(GX5CrNiMo13-4)
Stainless Steel CA6NM	IS 3444 Gr. 24	ASTMA 743 Gr. CA6NM	1.4313&1.4317(GX5CrNiMo13-4)
Chromium Stainless Steel Round Bar Material			
Stainless Steel 410	IS 1570 (part V) Gr. X12Cr12	ASTMA 276 type 410	1.4006(X10Cr13)
Stainless Steel 420	IS 1570 (part V) Gr. X20Cr13	ASTMA 276 type 420	1.4021(X20Cr13)
Stainless Steel 431	IS 1570 (part V) Gr. X15Cr16Ni2	ASTMA 276 type 431	1.4057(X20CrNi17)
Stainless Steel 316	IS 1570 (part V) Gr. X04Cr17Ni12Mo2	ASTMA 276 type 316	1.4401(X5CrNiMo17122)
Stainless Steel 316L	IS 1570 (part V) Gr. X02Cr17Ni12Mo2	ASTMA 276 type316L	1.4404(X2CrNiMo1810)
Cast Duplex Steel			
Duplex Steel 1A		ASTMA 890 Gr. CD4MCu	25Cr-5Ni-Mo-Cu
Duplex Steel 2A		ASTMA 890 Gr. CE8MN	24Cr-10Ni-Mo-N
Duplex Steel 3A		ASTMA 890 Gr. CD6MN	25Cr-5Ni-Mo-N
Super Duplex steel 4A		ASTMA 890 Gr. CD3MN	25Cr-7Ni-Mo-N
Super Duplex steel 5A		ASTMA 890 Gr. CE3MN	24Cr-10Ni-Mo-N
Non Ferrous Materials			
Bronze	IS 318 Gr. LTB2 (CuSn5Zn5Pb5C)	ASTMB 584 - C90500	DIN 1705 Rg 5
Phosphor Bronze	IS 28 Gr. 1 (CuSn11PC)		
Zinc Free Bornze	IS 28 Gr. 1 (CuSn10C)		

FAMILY CURVES

Family Curve of KPD Process Pump at 1450 rpm- 50Hz

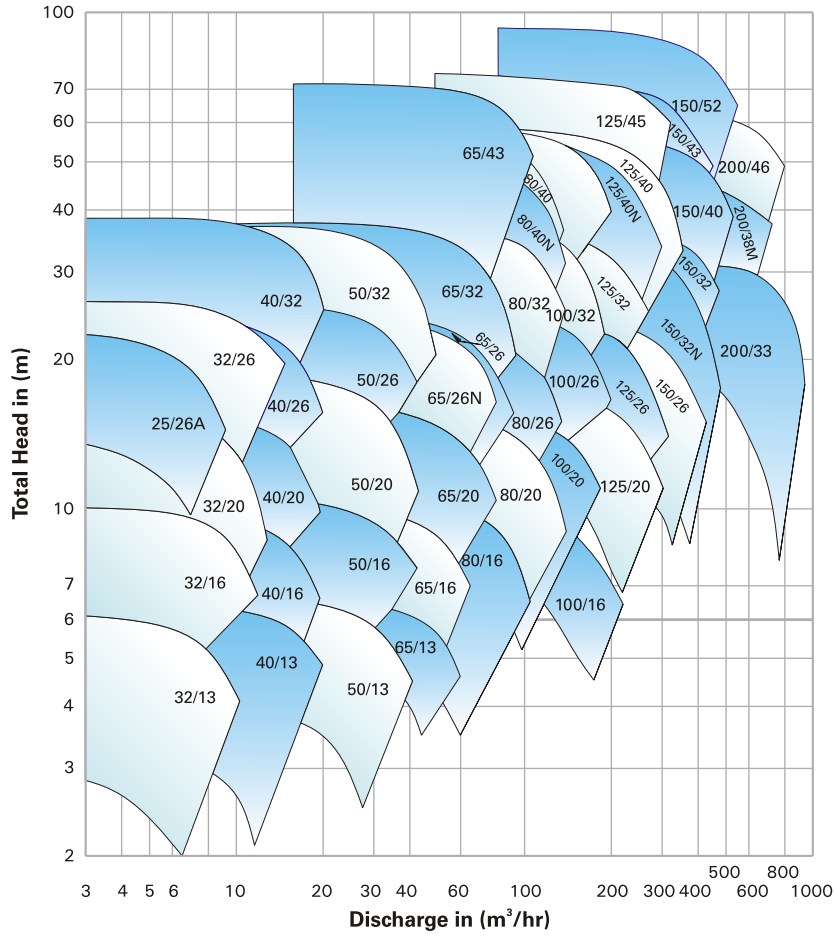

Family Curve of KPD Process Pump at 2900 rpm- 50Hz

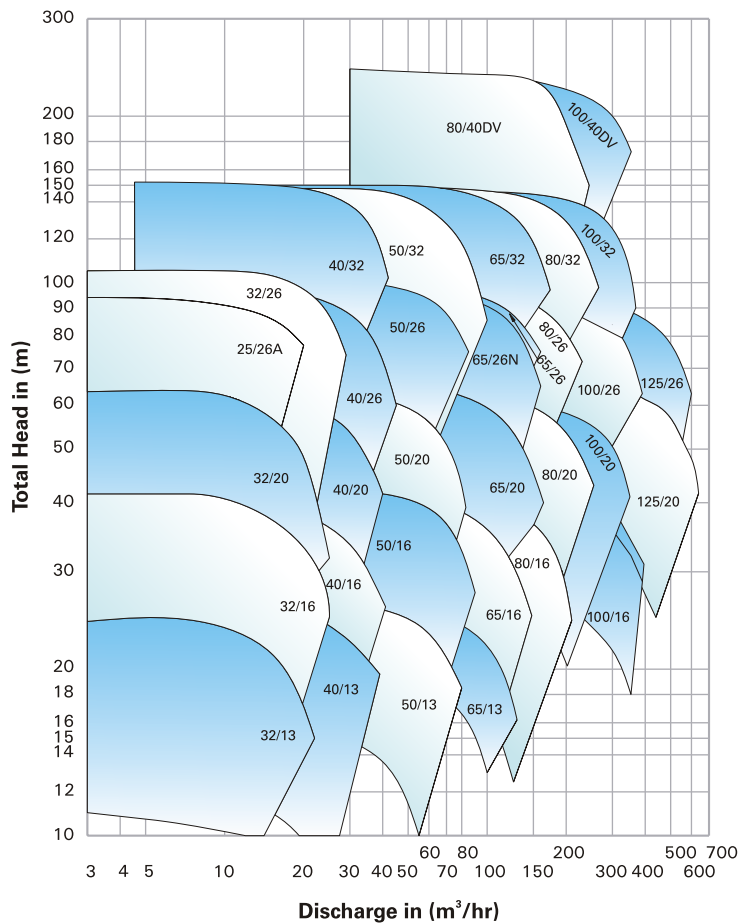

Family Curve of KPD-QF Process Pump at 1450 rpm 50 Hz

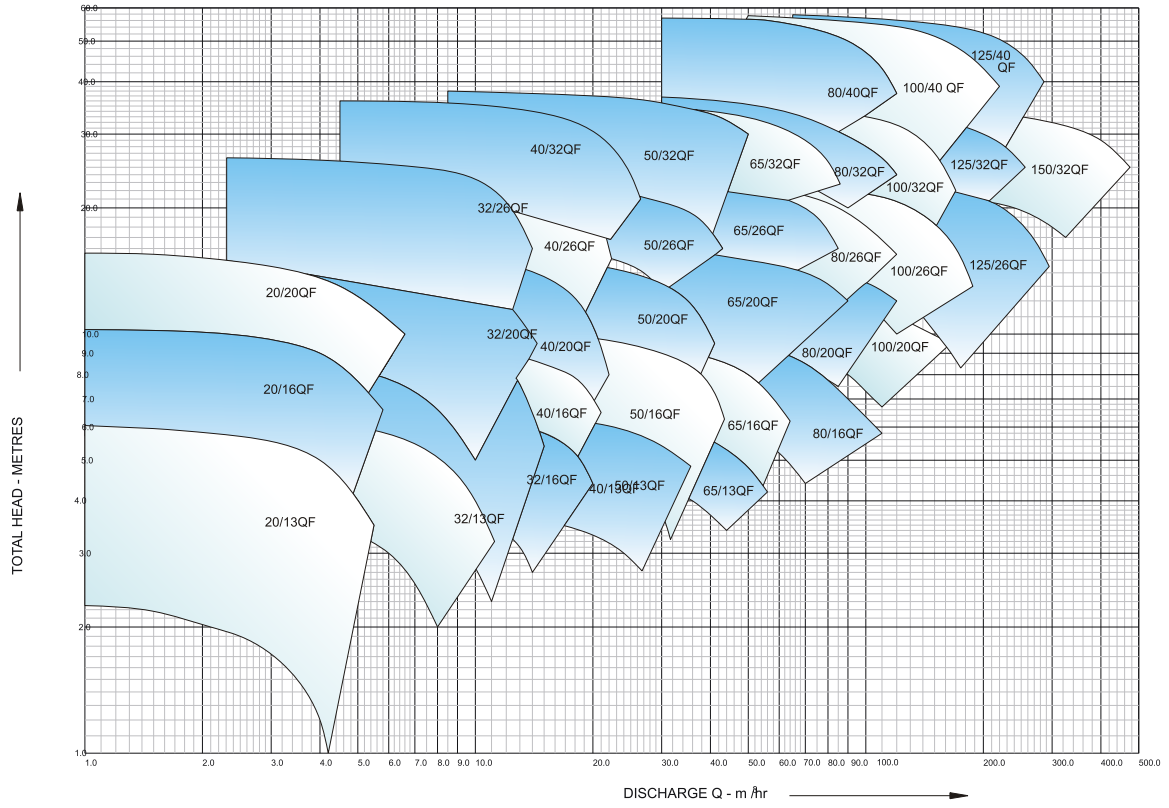

Family Curve of KPD-QF Process Pump at 2900 rpm 50 Hz

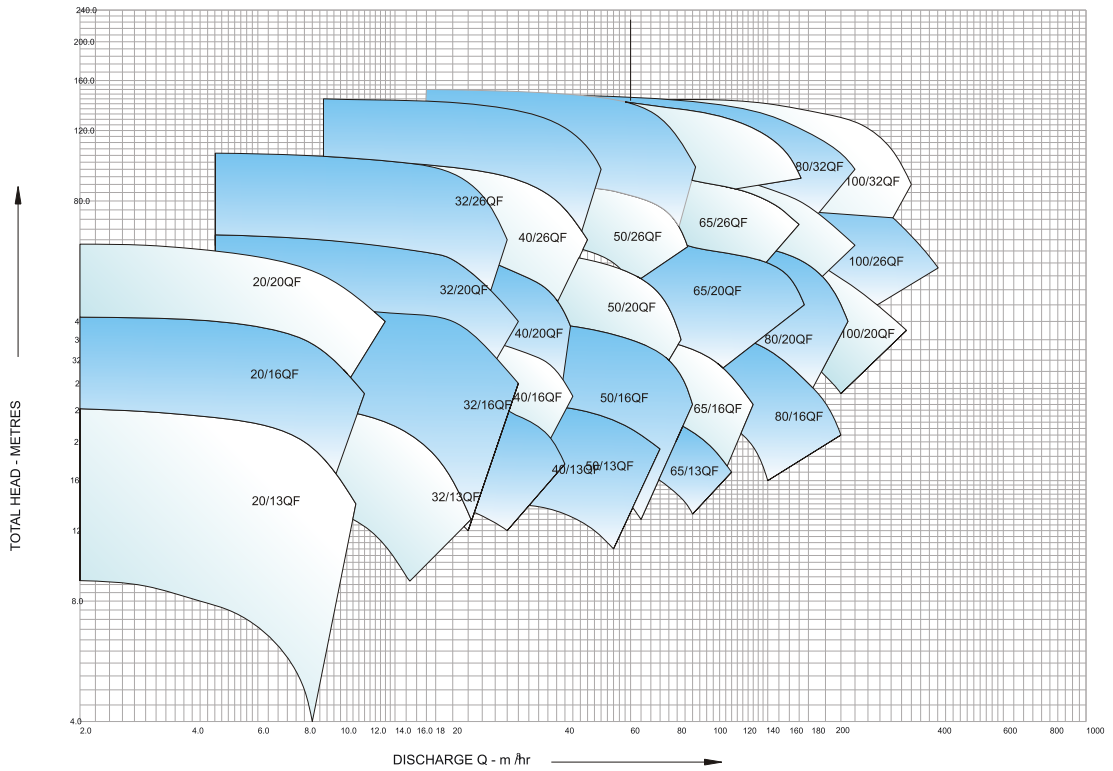

OUR GLOBAL PRESENCE



As we are constantly endeavouring to improve the performance of our products/ equipment, we reserve the right to make alterations from time to time and as such our products/ equipment may differ from that detailed in this publication. For latest information you may get in touch with our Regional Sales Offices.



Enriching Lives

KIRLOSKAR BROTHERS LIMITED

CORPORATE OFFICE :

"YAMUNA", Survey No. 98 (3/7), Baner,
Pune - 411045, INDIA
Tel.: +91 20 27214444 Fax: +91 20 27211117
email: kbilin@kbl.co.in website: www.kbl.co.in

WORKS :

Kirloskarvadi 416308 Dist. Sangli
Maharashtra, INDIA
Tel.: +91 2346 222301 to 222305
Fax: +91 2346 222311

